

# SGE-EM 2MW-Class Gas Engines & Gensets

E-Series Engines

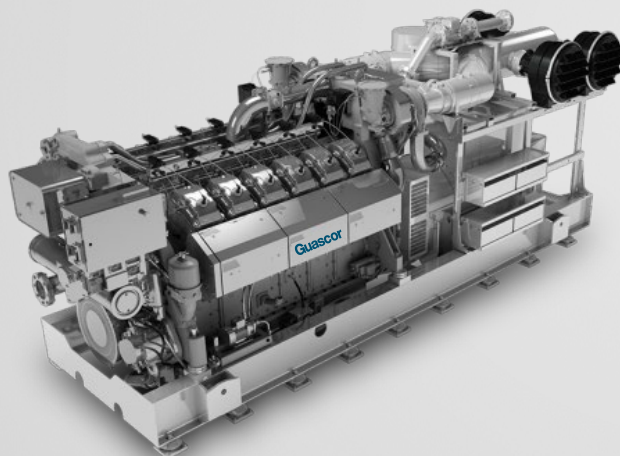

## The new best-in-class solution for more efficient power generation.

In the past, when it came to choosing a 2 MW-class engine, your options were limited. Now, there's a powerful new choice available that delivers the highest electrical efficiency in the smallest footprint: the new SGE-EM gas engines from Guascor Energy.

- Unique high-volume 12-cylinder design delivers highest displacement
- 90,000 hours until overhaul
- Innovative pre-combustion chambers provide efficient and stable combustion
- Spark-ignited lean-burn unit ensures low emissions
- Fast cycle times and implementation
- Smallest footprint in the competitive set
- Lowest emission version available 200 mg NOx

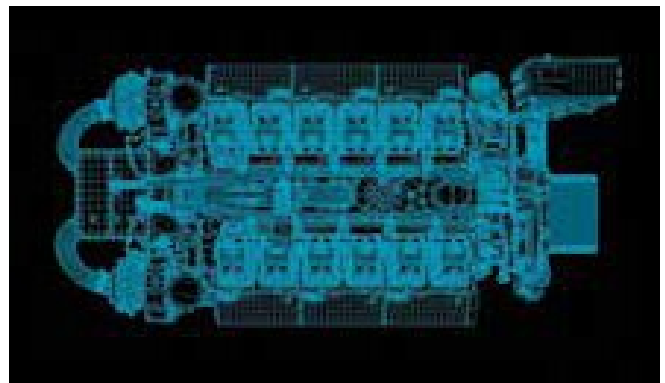
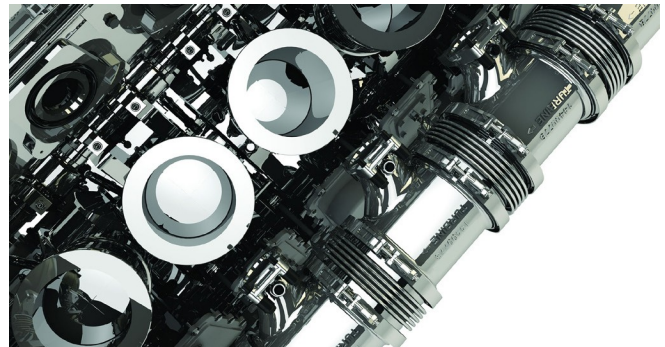

SGE	86EM	100EM
RPM	1,500	1,200
CYLINDER ARRANGEMENT	100	75
DISPLACEMENT	86 liters	100 liters
BORE	195 mm	195 mm
STROKE	240 mm	280 mm
COMPRESSION RATIO	13.5:1	13.5:1

SGE	86EM	100EM
BMEP*	19.2 bar	20.7 bar
MECHANICAL POWER	2,065 kWb	2,065 kWb
ELECTRICAL POWER	2,013 kW <sub>e</sub>	2,007 kW <sub>e</sub>
MECHANICAL EFFICIENCY	46.9%	46.7%
ELECTRICAL EFFICIENCY	45.7%	45.4%
GLOBAL EFFICIENCY	92,6%	92%

# The new best-in-class solution with the highest electrical efficiency.

*Our new 2 MW-class SGE-EM gas engines represent a new competitive choice*

*with the highest electrical efficiency and displacement in its category. All this power*

*and efficiency is available in the smallest footprint with industry-leading cycle times.*

## Innovative design and combustion technology.

To learn more about the new SGE-EM Gas Engines from Guascor Energy, visit [guascor-energy.com](http://guascor-energy.com)

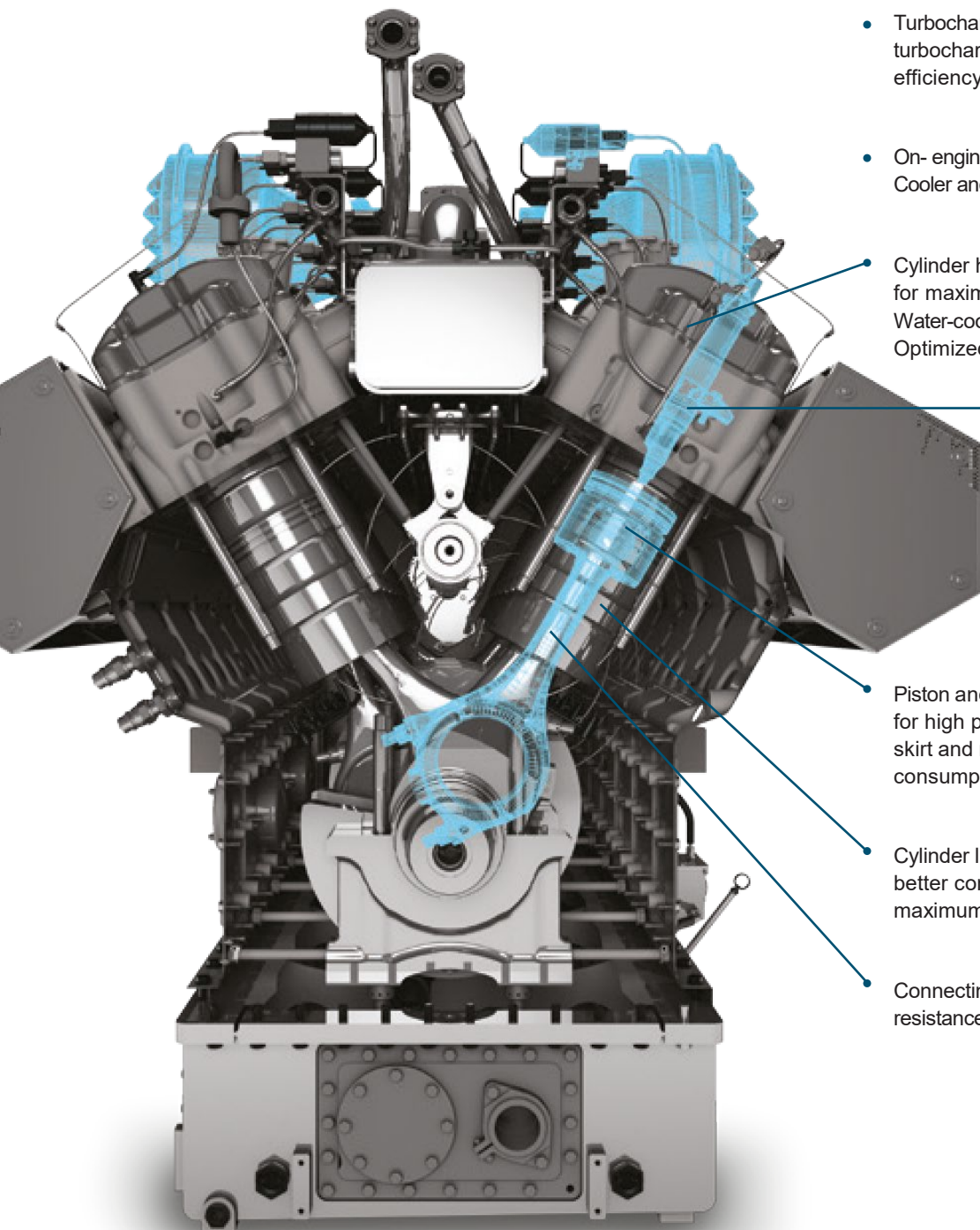

- Charge cooler—Two-stage charge cooler for increased engine performance.
- Turbochargers—High-efficiency turbochargers allow high engine efficiency. Water cooled for longer life.
- On- engine integrated and accessible Oil Cooler and Oil Pump
- Cylinder head—Minimum pressure losses for maximum volumetric efficiency. Water-cooled exhaust valve seats. Optimized cooling galleries.
- Pre-combustion chamber—Direct gas injection. Designed for best mixture distribution, allowing high engine efficiency with low emissions. Nickel-chromium superalloy material for high temperature resistance.
- Piston and rings pack—Forged steel piston for high peak combustion pressures, with skirt and rings design for best oil consumption control.
- Cylinder liner—Optimized cooled area for better combustion efficiency and maximum energy transfer to powertrain.
- Connecting rod—Low mass and high resistance for better dynamic behavior.

**Published by  
Guascor Energy**

Oikia, 44  
20759 Zumaia (Gipuzkoa) Spain  
PO Box 30  
Tel: (Int'l +34) 943 86 52 00  
Fax: (Int'l +34) 943 86 52 10

[www.guascor-energy.com](http://www.guascor-energy.com)

Subject to changes and errors. The information given in this document only contains general descriptions and/or performance features which may not always specifically reflect those described, or which may undergo modification in the course of further development of the products. The requested performance features are binding only when they are expressly agreed upon in the concluded contract.

© Guascor Energy 2022

Guascor Energy is a trademark licensed by Guascor Energy S.A.U